



**BRINGING
EFFICIENCY
TO HEAT
TRANSFER**

TABLE OF CONTENT

A global team with knowledge.....	3
GASKETED PLATE HEAT EXCHANGERS.....	4
Superchanger® Plate and frame for maximum efficiency.....	6
Thermofit™ plate series Featuring the unique Omniflex™ plate pattern.....	8
Complete Tranter® plate series.....	9
WELDED PLATE HEAT EXCHANGERS	16
Supermax® When conditions are tough... Think plates instead of tubes	18
NovusBloc® For increased durability and energy efficiency.....	22
TRANTER FULLSERV® FOR EVERY BRAND.....	24
Tranter FullServ® Restoring plate heat exchangers to optimized performance	26

A GLOBAL TEAM WITH KNOWLEDGE AND EXPERIENCE STRETCHING ACROSS ALL CONTINENTS

Tranter is an American based global manufacturer of gasketed and welded plate heat exchangers and a full service aftermarket provider for the plate heat exchanger industry. Significant manufacturing, research, design engineering and product develop-

ment activities are based in the USA, Brazil, Sweden, China, India and Korea and enable responsiveness to local demands. Tranter is represented globally by a network of our own sales companies, licensees and agents.



TRANTER.COM



GASKETED PLATE HEAT EXCHANGERS

Tranter provides a large range of plate heat exchangers for a variety of applications. The plate heat exchangers are built on a module-based concept and are designed to provide maximum efficiency in transferring heat from one liquid to another, or from steam to liquid. Frames, plates and connections can be combined to form a number of different exchanger types. By using different types of plates, with different characteristics, the heat exchangers can be adapted to a wide variety of applications. The benefit of the gasketed plate heat exchanger is that it can easily be expanded or adapted, by adding or replacing plates when conditions change.



SUPERCHANGER®

Plate and frame for maximum efficiency

OPTIMUM PERFORMANCE IS A PROMISE TRANTER HAS BEEN FULFILLING FOR MANY DECADES WITH SUPERCHANGER PLATE AND FRAME HEAT EXCHANGERS. TRANTER SPECIALIZES IN PROVIDING HEAT TRANSFER SOLUTIONS IN ALL INDUSTRIES. OUR COMPLETE ENGINEERING AND MANUFACTURING EXPERTISE BRINGS YOU EQUIPMENT THAT MEETS THE HIGHEST STANDARDS OF DESIGN EXCELLENCE AND QUALITY WORKMANSHIP.

GOT INCREASED PRODUCTION AND BUDGET DEMANDS?
GET EFFICIENT, COST-EFFECTIVE SOLUTIONS WITH TRANTER HEAT TRANSFER TECHNOLOGY.

EFFICIENT AND RELIABLE HEAT TRANSFER FOR EVERY INDUSTRY

The Superchanger is Tranter's trademarked gasketed plate heat exchanger. Superchanger are ubiquitous, and they can be found operating across the globe today on offshore oil platforms, in the basements and on the rooftops of casinos, hospitals, and universities, in chemical plants, refineries, gas processing facilities, amusement

parks, data centers, and breweries. You will see them in the utility rooms of geothermal pool resorts, in power plants, automobile factories, steel mills, elementary schools, and in about half of all ethanol plants in North America. These are just few of the many applications that utilize Superchanger.

The plates and gaskets for Tranter's Superchanger are designed by Tranter engineers at our R&D headquarters in Houston, Texas, USA. They are designed to achieve specific goals such as higher pressure ratings, more efficient heat transfer with lower pressure drop, and to handle tough media such as streams with a high particulate load. Our global engineering team is constantly checking the market for new trends that may require different designs, and Tranter regularly launches new plate designs.

Tranter's sizing software is fully designed by staff engineers and includes optional AHRI 400 certified

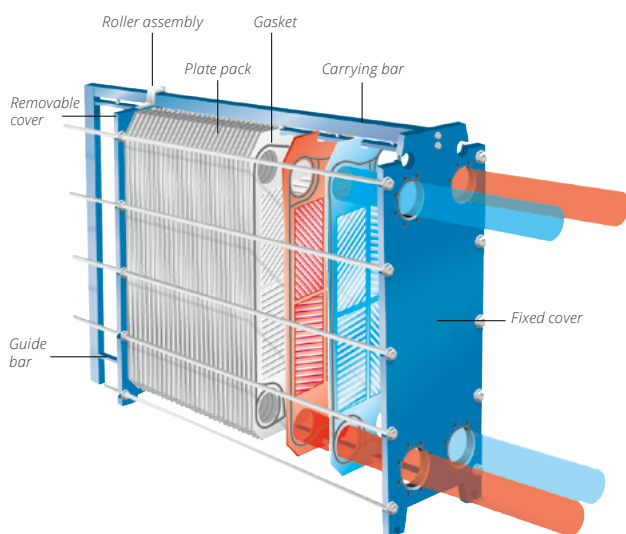

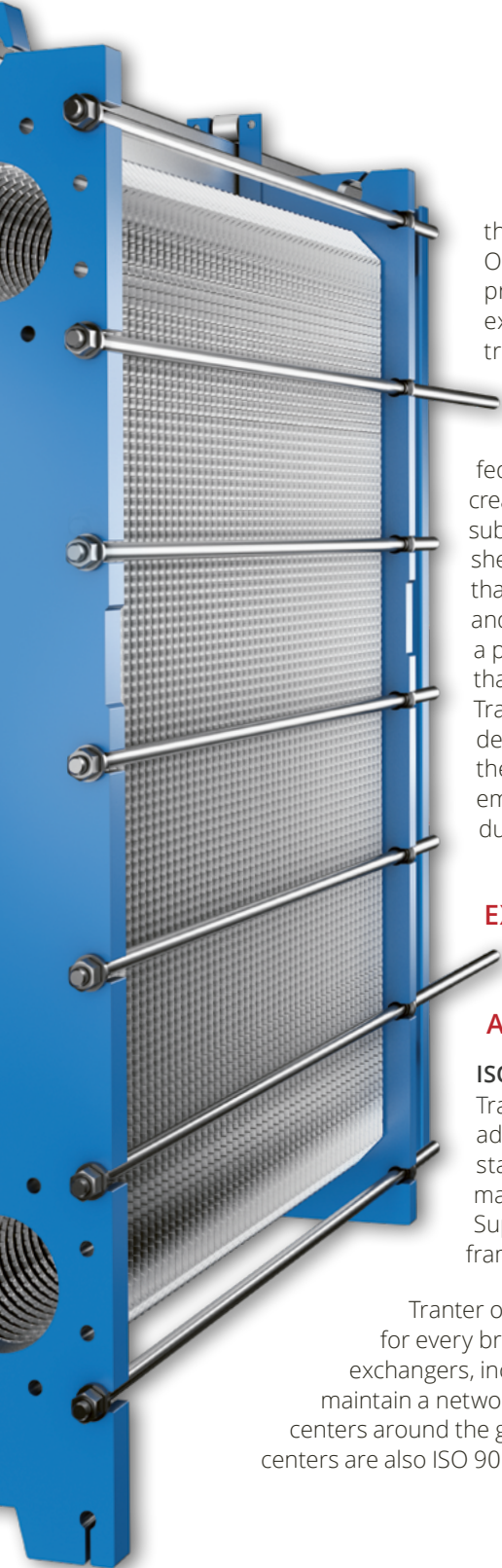

thermal performance. Once designed and pressed, Tranter plates are extensively tested for heat transfer and pressure-drop characteristics to obtain a base of empirical data which is fed into the algorithms to create sizings. When Tranter submits a performance data sheet, it is generated by that same sizing program and that sheet represents a performance guarantee that Tranter stands behind. Tranter performance details are not based on theoretical data, but on the empirical data gathered during testing.

**EXCEPTIONAL SERVICE
MANUFACTURING,
SUPERIOR TESTING,
AND SERVICING**

ISO 9001 certification
Tranter is ISO certified, adhering to the highest standards in designing, manufacturing, and testing Superchanger plate and frame heat exchangers.

Tranter offers exceptional service for every brand of plate heat exchangers, including its own. We maintain a network of Tranter service centers around the globe. These service centers are also ISO 9001 certified, and provide

refurbishment services for heat exchangers and plate packs. In addition, they are staffed with field-service technicians ready to dispatch to your location to provide on-site service.

Finally, Tranter’s innovation center in Houston is a unique lab where creative design ideas are imagined and verified, and heat exchangers can be examined under a variety of hot and cold full-flow testing conditions with a variety of flow media. Even customer testing requests can be accommodated.

HOW SUPERCHANGER PLATE HEAT EXCHANGERS OUTPERFORM SHELL AND TUBE UNITS

Superchanger heat exchangers transfer heat more efficiently than shell and tube units in most applications, due in large measure to the turbulent flow created by the corrugated patterns of their plates. They can pack greater than 2,000 m² (22,000 ft²) of super-efficient heat transfer surface in a single unit with flow rates up to 5,750 m³/h (25,400 gpm). They use only 10-50% of the space required by shell and tube units and are much lighter in weight.

Flow ranges	0 – 5,750 m ³ /h
Max work pressure	25 bar / 363 psi
Temp range	-40 to 180C° / -40 to 356F°
Connections	DN 25-500 / 1" - 20" Weld neck, flange or threaded

*Specifications may be changed without prior notice.
Please contact us for specific details.*

THERMOFIT™ PLATE SERIES

Featuring the unique Omniflex™ plate pattern

TRANTER PROVIDES INDIVIDUAL PLATE ASSEMBLIES (WITH GASKET ALREADY ATTACHED) OR ENTIRE PLATE PACKS FOR YOUR SPECIFIC HEAT EXCHANGER, INCLUDING TRANTER AND NON-TRANTER BRANDS.

INNOVATION TO GREATER ENERGY EFFICIENCY

Sustainable energy utilization has become a global imperative. Tranter's wide range of gasketed plate and frame heat exchangers enables our customers to reduce their energy consumption and the greater thermal efficiency of the heat exchanger the more energy can be saved. Therefore, Tranter has developed highly efficient and innovative plate models in the plate series called ThermoFit, which will enable our customers to save even more energy!

OMNIFLEX PLATE PATTERN

The Omniflex plate pattern – A patented Tranter design enabling high energy efficiency. The unique plate pattern induce high turbulence and enhanced heat transfer rates, yet achieves low-pressure drop.

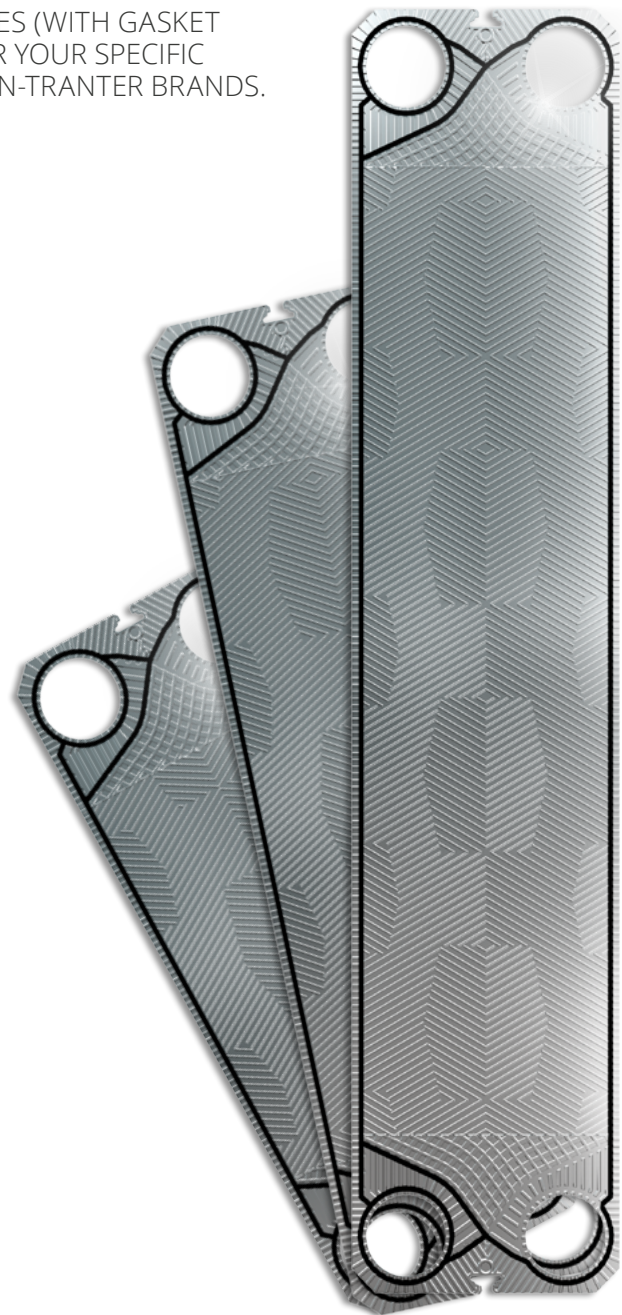

COMPLETE TRANTER® PLATE SERIES

ULTRAFLEX PLATES (GX)

Especially when flows are unbalanced and the allowable pressure drops are reasonably close, Tranter utilises its GX series plate designs. Tranter's corrugated GX plates have a gasket along the periphery. There are also gaskets around two of the four ports, which means that only one of the two fluids has access to the heating surface. The next plate has gaskets around the other two ports. Thus, a channel system is created where two fluids pass through every other channel respectively. Leakage between the two fluids is not possible thanks to double gaskets around the ports.

Tranter's unique, patented Ultraflex plate design features two angles for each plate size. The plates are available with a herringbone pattern with either a flat or sharp angle, making it possible to achieve six combinations of channels. An flat angle (high-theta plate) gives high resistance, and an sharp angle (low-theta plate) a low pressure drop. This allows our heat exchangers to be optimised for the characteristics for each individual application. If you have different flow rates in the primary and secondary circuits, your plate heat exchangers can be designed with asymmetrical channels for maximum heat transfer efficiency and economy.

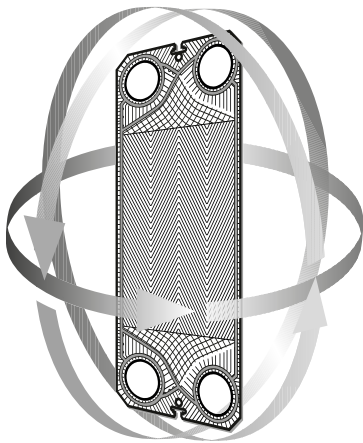

Our unique Ultraflex design allows the two plates to be turned and rotated, giving six combinations of high- and low-theta plate pairs, matching the performance parameters of your application.

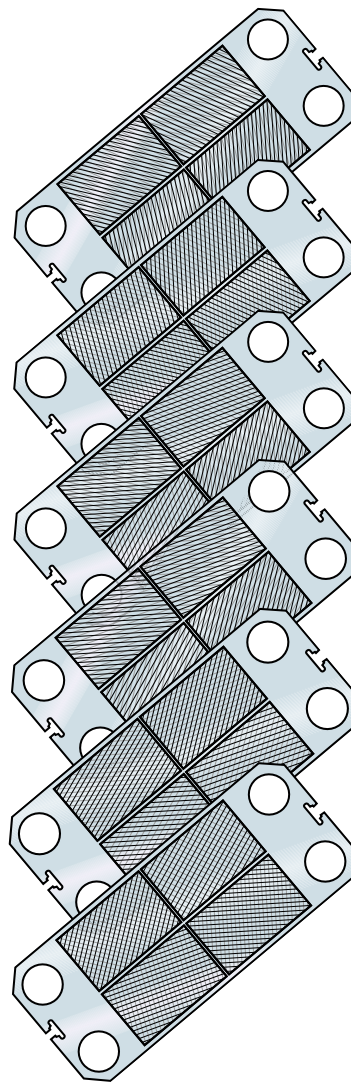

HS = High-theta
same direction

HD = High-theta
different directions

MS = Medium-theta
same direction

LS = Low-theta
same direction

LD = Low-theta
different directions

MD = Medium-theta
different directions

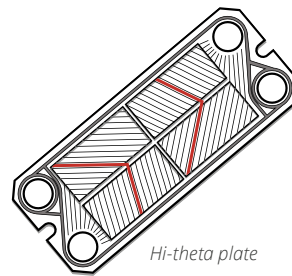

Hi-theta plate

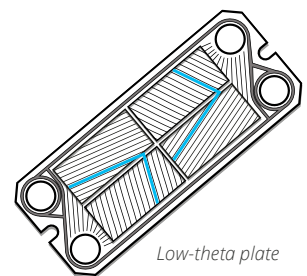

Low-theta plate

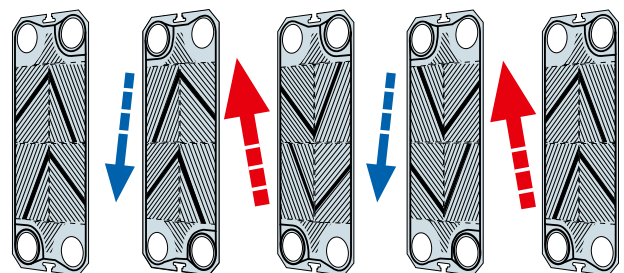

Ultraflex allows asymmetrical designs, with each circuit individually optimised for heat transfer.

GT PLATE SERIES – THE GREATER THERMAL EFFICIENCY OF THE HEAT EXCHANGER THE MORE ENERGY CAN BE SAVED

The GT series features a deeper gasket groove for higher pressures – up to 450 psig, a shallow draw depth for tight temperature approaches, and an inside-out halo alignment system. The series is specifically designed for HVAC or other tight-temperature-approach applications. Models available in 6” in and higher port-sizes. The plate series features HydroFit -variable draw depth to help distribute flow from port to heat transfer area and the Omniflex plate pattern – A patented Tranter design enabling high energy efficiency. The unique plate pattern induces high turbulence and enhanced heat transfer rates, with low pressure drop.

The GT-155 is interchangeable with other Tranter models and comes AHRI certified thus enabling improved energy efficiency in existing installations. The GT-165 is designed for optimized energy efficiency in District heating and cooling applications with LMTDs as low as 1 degree Kelvin.

Type	Connection size
GTP-155	DN 150
GTP-160	DN 150
GTP-165	DN 150
GTP-207	DN 200
GTP-211	DN 200
GTP-216	DN 200
GTP-305	DN 300
GTP-315	DN 300
GTP-325	DN 300
GTP-360	DN 350
GTP-370	DN 350
GTP-380	DN 350
GTP-410	DN 450
GTP-420	DN 450
GTP-430	DN 450
GTP-520	DN 500
GTP-530	DN 500

GX PLATE SERIES

Especially when flows are unbalanced and the allowable pressure drops are reasonably close, Tranter utilizes its GX series plate designs. Tranter’s corrugated GX plates have a gasket along the periphery. There are also gaskets around two of the four ports, which means that only one of the two fluids has access to the heating surface. The next plate has gaskets around the other two ports. Thus, a channel system is created where two fluids pass through every other channel respectively. Leakage between the two fluids is not possible thanks to double gaskets around the ports. Tranter’s unique, patented Ultraflex plate design features two angles for each plate size. The plates are available with a herringbone pattern with either an acute or obtuse angle, making it possible to achieve six combinations of channels. An obtuse angle (high-theta plate) gives high resistance, and an acute angle (low-theta plate) a low pressure drops. This allows our heat exchangers to be optimized for the characteristics for each individual application. If you have different flow rates in the primary and secondary circuits, your plate heat exchangers can be designed with asymmetrical channels for maximum heat transfer efficiency and economy.

Type	Connection size
GXD/GXP-026	DN 100
GXD/GXP-042	DN 100
GXD-051	DN 150
GXD-064	DN 150
GXD-091	DN 150
GXD-118	DN 150
GXD-060	DN 200
GXD-100	DN 200
GXD-140	DN 200
GXD-085	DN 300
GXD-145	DN 300
GXD-205	DN 300

GCP PLATE SERIES

Applications where low pressure drop is required or unit sizing is limited by pressure drop (low theta) are a perfect match for the GCP series plate. Tranter's GCP plate series are designed with a conventional herringbone pattern, with the gasket groove in the bottom plane. The plate design uses parallel flow direction, in contrast to the GX series, which features diagonal flow across the plate. Due to the deeper draw depth and the pattern in the flow distribution area, the GCP series plates yield a significantly lower pressure drop than the corresponding GX series plates. Both high- and low-theta versions are available in all three GCP series plates. This allows the flexibility to satisfy a wide range of applications.

Standard plate materials are EN 1.4301 (304SS), EN 1.4401 (316SS), and titanium, but requirements for hastelloy C-276, 254SMO or other cold-formed alloys can be accommodated. Standard gasket materials are NBR, EPDM and fluor elastomer.

Type	Connection size
GCP-026	DN 100
GCP-052	DN 150

GCD plate series

GCD plate series are ideal for applications with very small temperature differences. GCD-016, GCD-044 and GCD-054 plates are designed with a conventional herringbone pattern, diagonal flow direction and with the gasket groove in the bottom plane.

Standard plate materials are EN 1.4301 (304SS) and EN 1.4401 (316SS). Standard gasket material is NBR.

Type	Connection size
GCD-008	DN 32
GCD-009	DN 40
GCD-016	DN 50
GCD-044	DN 100
GCD-054	DN 150

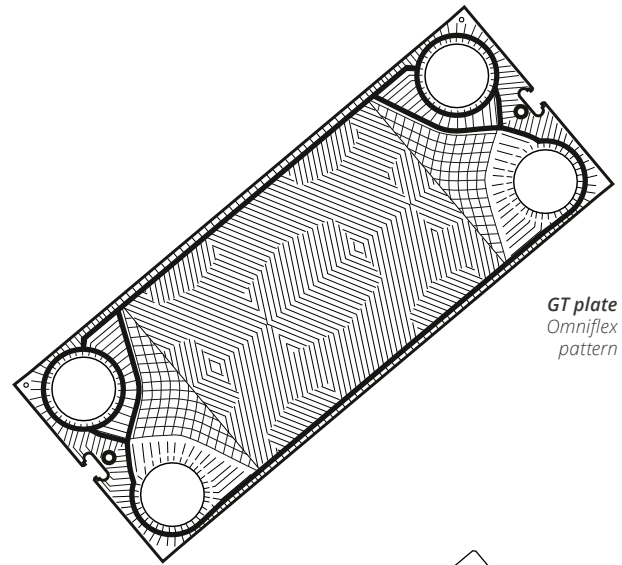

*GT plate
Omniflex
pattern*

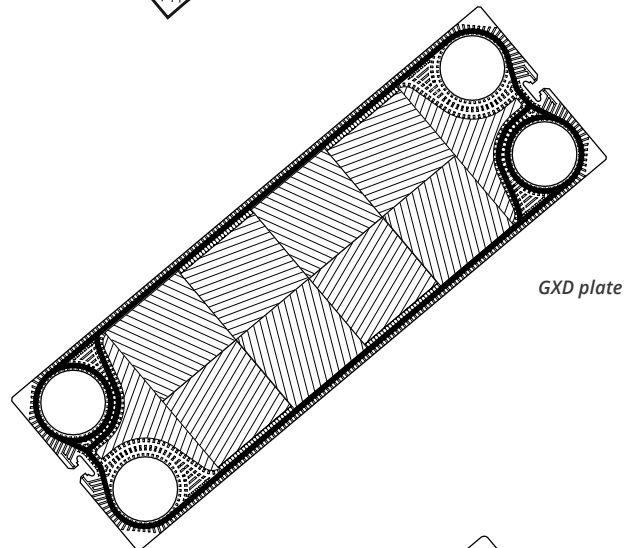

GXD plate

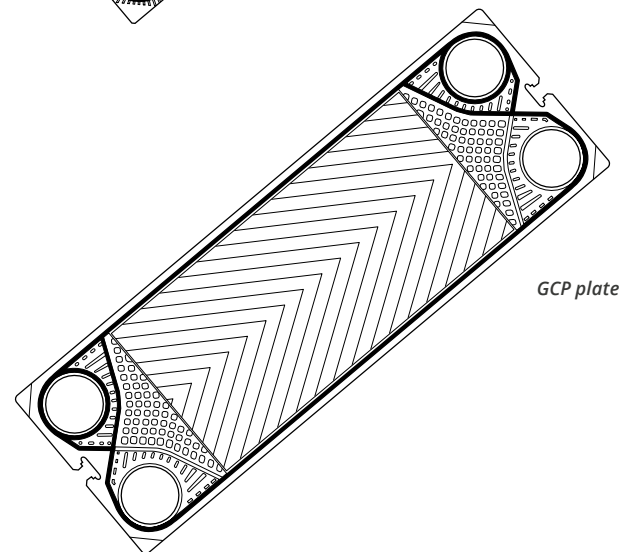

GCP plate

GFP WIDE-GAP PLATES DEFEAT CLOGGING AND DOWNTIME

A plate and frame heat exchanger utilizing wide-gap plates economically recovers heat from hard-to-handle waste streams in a variety of industries, including pulp and paper, sugar processing, alcohol production, grain processing, chemicals, textiles and ethanol distilling.

Standard materials are EN 1.4301 (304SS) and EN 1.4401 (316SS). Custom requirements for hastelloy C-276, 254SMO or other alloys, which can be cold formed, can also be accommodated.

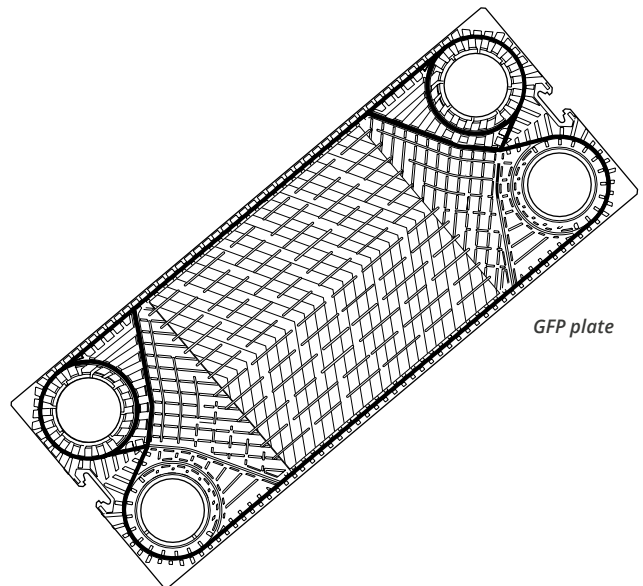

Type	Connection size
GFP-057	DN 200
GFP-097	DN 200
GFP-187	DN 200
GFP145	DN 300
GFP-206*	DN 300

*GF-206 replaced GF-205

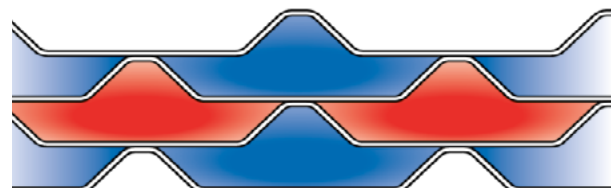
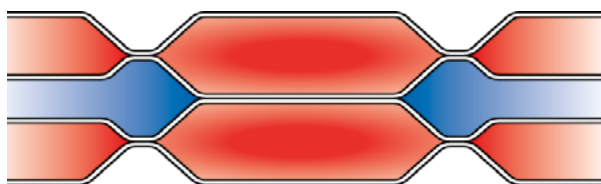

GL PLATE SERIES

GL series herringbone-style plates have a large theta span, enabling finely tuned pressure drop and heat transfer rate.

Type	Connection size
GLP-004	DN 32
GLP-008	DN 32
GLD-009	DN 40
GLD-013	DN 50
GLD-085	DN 300
GLD-145	DN 300
GLD-152	DN 350
GLD-218	DN 350

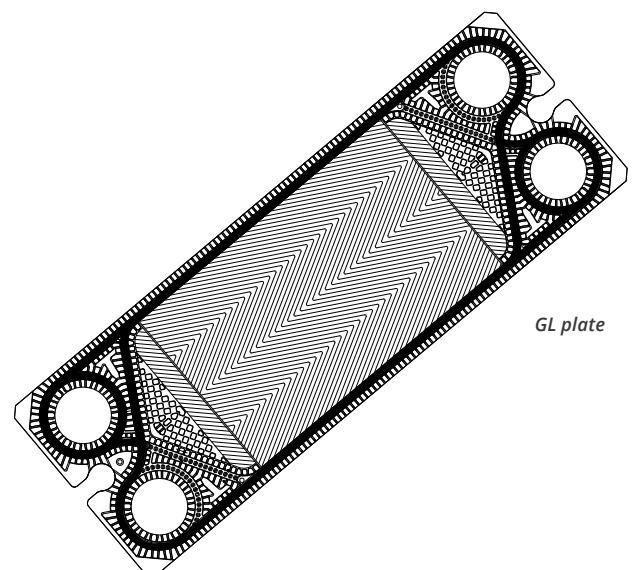

UXP PLATE SERIES

The UXP series has a tight pitch for higher heat transfer and has corrugations in a traditional herringbone or chevron pattern. Steep and shallow angles are both available according to the requirements of the applications. It is most efficient with relatively clean solutions due to the greater induced turbulences within the flow stream.

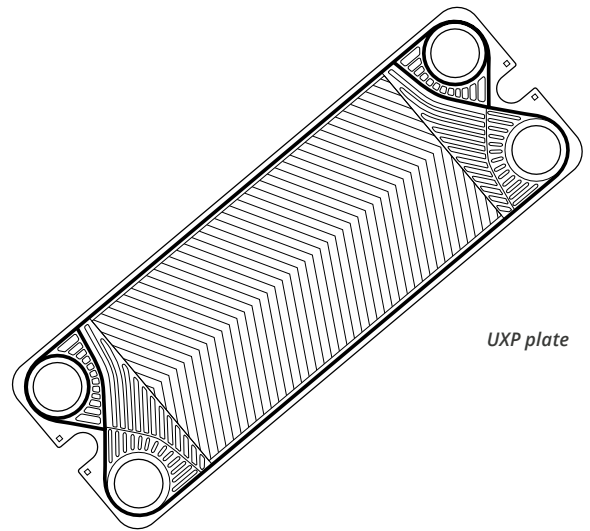

GD PLATE SERIES

The double-wall plate heat exchanger is intended for use where the two fluids on each side of the plates should not mix—due to possible contamination or an undesirable reaction. If a leak through one of the plates or around one of the gaskets should occur, the fluid is vented to the outside of the heat exchanger before any intermixing can occur. The leak is immediately evident even before disassembly of the heat exchanger.

Some popular industries and applications that utilize GD series plates include:

- Pharmaceutical industry
- Food & beverage industry
- District heating
- Cooling of transformer oil
- De-ionized water
- Potable water

The possibility of intermixing is virtually eliminated by nesting two plates together and welding the port holes.

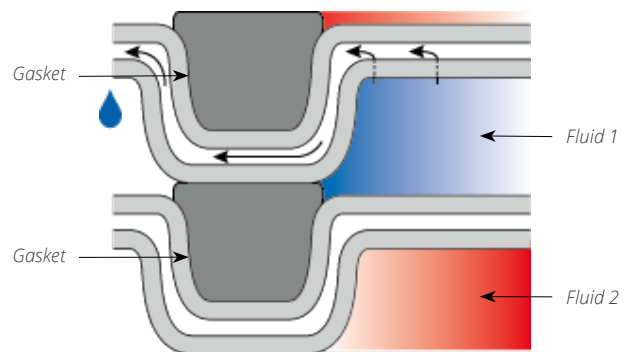

The nested plates are gasketed and assembled to form the plate pack.

GASKET CHOICE

Glued gaskets

Tranter plate gaskets are specially moulded elastomers to assure superior performance.

Numerous gasket materials—NBR, EPDM, viton, neoprene, butyl, hypalon, teflon-encapsulated NBR and others—are available to match your process conditions, to maximum operating temperatures of 180°C

Clip-on gaskets

Consider the Tranter clip-on glueless gasket system wherever regular cleaning is necessary or aggressive fluids shorten gasket life. The unique design allows easy and fast clip-on installation for sure sealing and simple removal.

The clip-on is available in NBR and EPDM, both industrial and FDA ratings. These precision gaskets are moulded under rigorous manufacturing controls and are peroxide-cured for long life and excellent compression set resistance.

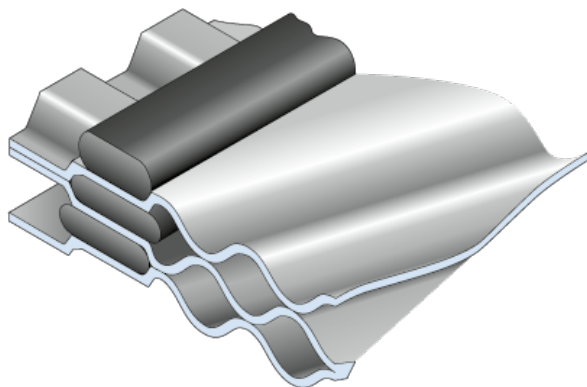
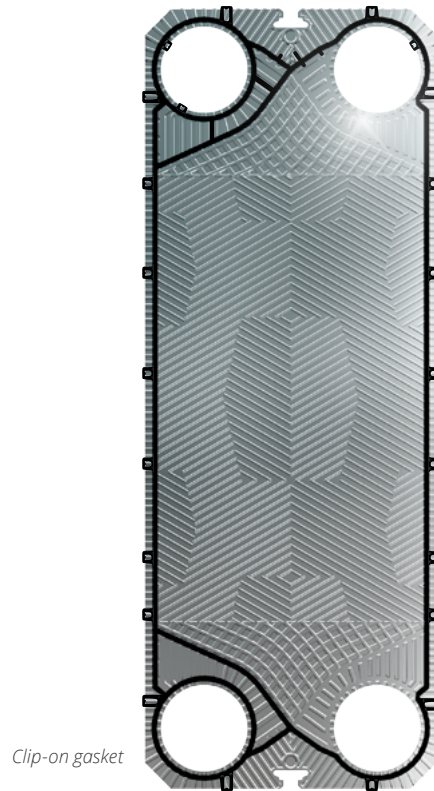

Gaskets on GX Series plates are located in the neutral axis.

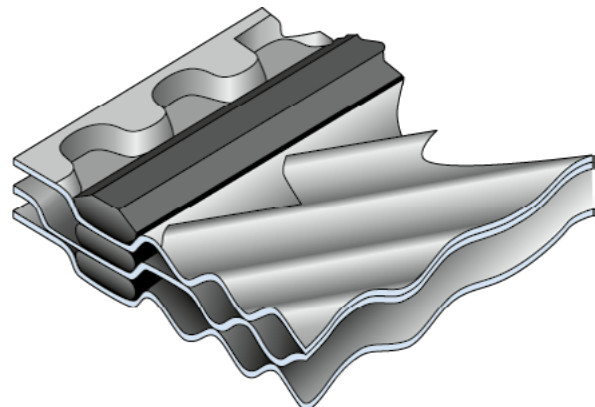

Gaskets on all other plates are located in tapered grooves.



TEGERA®

GREEN

JAGIE

COMFORT, LEADERS, SPEED



WELDED PLATE HEAT EXCHANGERS

Compact heat exchangers for extreme temperatures, pressures and special designs that exceed gasket limitations. They offer high performance, small sizes, and minimal maintenance. The exchangers can handle liquids, gases, and two-phase mixtures at very high pressures and at low and high temperatures. They are manufactured to meet customer needs for the highest quality and efficiency.



SUPERMAX[®]

When conditions are tough... Think plates instead of tubes

NOW YOU CAN OBTAIN THE THERMAL EFFICIENCY AND COMPACTNESS OF GASKETED HEAT EXCHANGERS IN ELEVATED PRESSURE/HIGH- AND LOW-TEMPERATURE APPLICATIONS. TRANTER'S WELDED PLATE HEAT EXCHANGERS ALLOW YOU TO ATTAIN HIGH HEAT TRANSFER RATES UNDER ELEVATED PROCESS CONDITIONS, IN LESS SPACE AND AT LOWER COST THAN SHELL AND TUBE EXCHANGERS.

SUPERMAX – FOR AMAZING EFFICIENCY IN A SMALL FOOTPRINT

The Supermax shell and plate heat exchanger is designed for pressures to 103 barg (1,500 psig) and at temperatures up to 448°C (840°F) for standard range units. Extended range units are available for higher temperature and pressure applications. Optional Supermax configurations meet special needs.

Turbulent flow, even at low velocities, enables stable capacity regulation and minimizes fouling. In refrigeration and cryogenic service, the exchangers require a low refrigerant charge. They are also resistant to freezing because of high fluid turbulence induced by the corrugated plate pattern. Supermax wide temperature/pressure ratings offer good performance with natural refrigerants such as ammonia and carbon dioxide.

Fluids can undergo phase change on either the plate or shell side. The Supermax is particularly suited to applications having a large flow imbalance, allowing higher flow rates on the shell side. The Supermax can be installed horizontally or vertically; horizontal installation is recommended for condensing/ evaporating/boiling applications.

THE RIGHT MATERIALS FOR THE JOB

Supermax plate materials may be type 316L stainless steel, hastelloy C-276, AL6XN, SMO254 or other alloys;

shells may be fabricated of carbon steel, types 304, 316, 316L stainless steel or titanium. The unit can be fabricated from dissimilar metals when only one side will be exposed to corrosive conditions.

SUPERMAX SHELL AND PLATE ROUND EXCHANGER CONNECTIONS

Plate model	Plate side connections	Shell-side connections
SPW-30	DN 50 / ANSI 2"	DN 20-150 / ANSI 0.75"-6"
HPW-30	DN 50 / ANSI 2"	DN 20-150 / ANSI 0.75"-6"
DPW-30 ²	DN 50 / ANSI 2"	DN 20-150 / ANSI 0.75"-6"
SPW-40	DN 80 / ANSI 3"	DN 25-250 / ANSI 1"-10"
DPW-40 ²	DN 80 / ANSI 3"	DN 25-250 / ANSI 1"-10"
SPW-55	DN 100 / ANSI 4"	DN 32-350 / ANSI 1-1/4"-14"
DPW-55 ²	DN 100 / ANSI 4"	DN 32-350 / ANSI 1-1/4"-14"
SPW-75	DN 150 / ANSI 6"	DN 50-500 / ANSI 2"-20"
SPW-83	DN 150 / ANSI 6"	DN 50-500 / ANSI 2"-20"
SPW-101	DN 200 / ANSI 8"	DN 100-700 / ANSI 4"-28"
DPW-101 ²	DN 200 / ANSI 8"	DN 100-700 / ANSI 4"-28"

¹Dual inlets on both plate and shell sides are available.
²Deep draw depth plate.

THE CHEVRON PLATE

The chevron-type plates are fabricated into a cassette by full automatic welding in the port hole (1). These cassettes are then stacked together and perimeter welded to each other (2), producing an accordion-like core which is highly tolerant to thermal expansion.

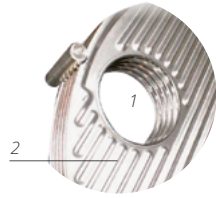

The plate pack is then inserted in a cylindrical shell. The shell and plate pack are fitted with special fluid diverters to ensure proper flow throughout the unit. End plates, connections and top & bottom covers are welded to the shell to form a pressure vessel of high integrity. Extra large connection sizes can be selected on the shell side of the heat exchanger.

The plates are adjusted within the shell to optimise flow distribution and performance. Supermax units can be designed in for co-current, counter-current and cross-flow duties. Plates can also be arranged to form multiple passes.

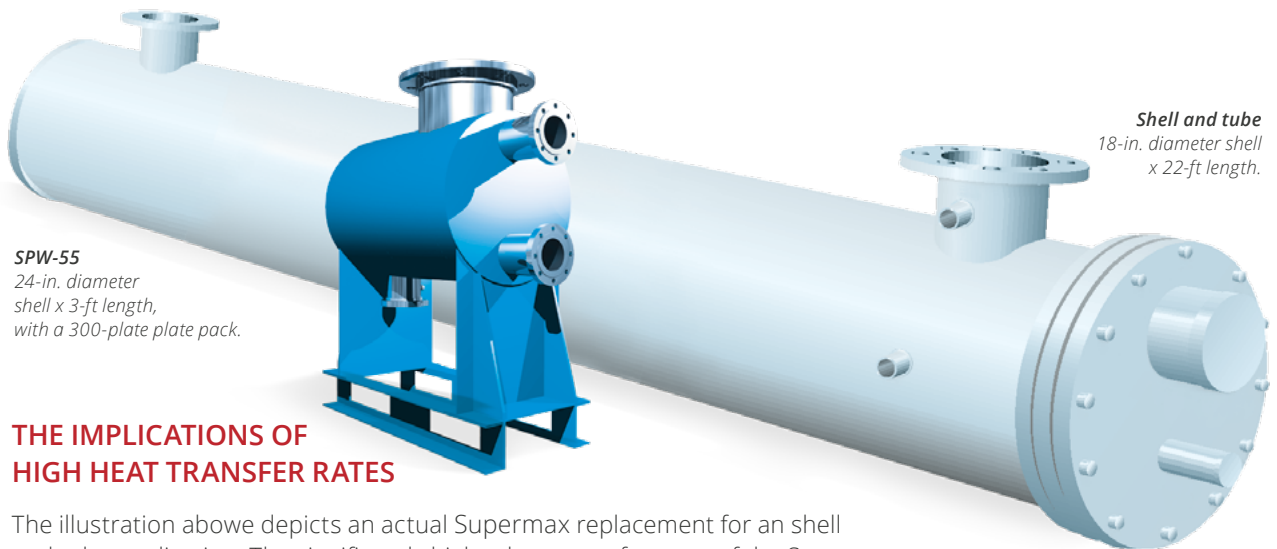
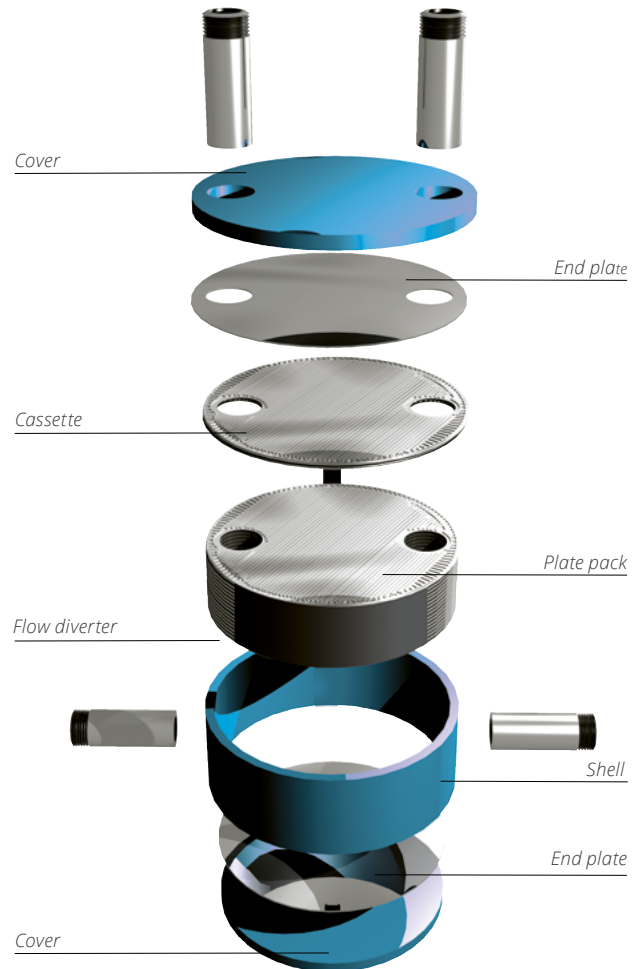
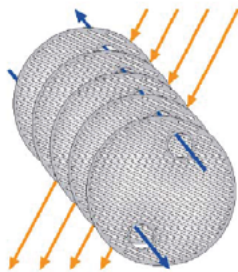

SPW-55
24-in. diameter shell x 3-ft length, with a 300-plate plate pack.

Shell and tube
18-in. diameter shell x 22-ft length.

THE IMPLICATIONS OF HIGH HEAT TRANSFER RATES

The illustration above depicts an actual Supermax replacement for an shell and tube application. The significantly higher heat transfer rates of the Supermax plates versus the tube bundle are responsible for the striking difference. The implications are clear: less cost for materials (stainless steel, titanium or other expensive higher alloys), simpler fabrication for shorter delivery lead times, easier installation, simpler support structures and vastly smaller footprints, especially considering dead space required to pull the shell and tube bundle for cleaning.

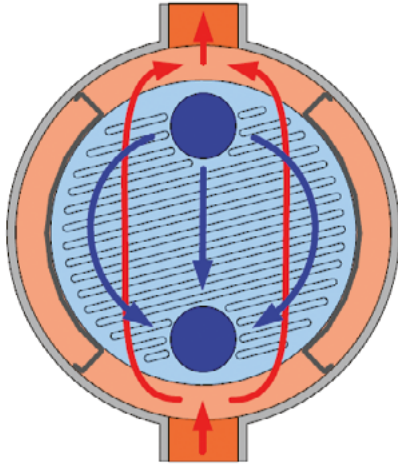

Flow distribution on the shell side (red) and on the plate side (blue).

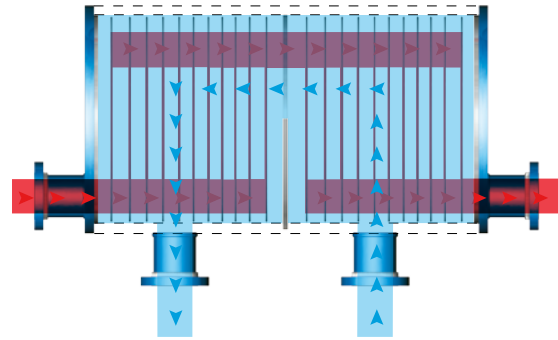

Supermax plates can be arranged to form multi passes on both the plate and shell sides.



The Supermax with removable core provides full access to the plate pack for inspection and/or mechanical cleaning.



Supermax plates can be manufactured from stainless steel 316L, 254 SMO, hastelloy and titanium as standard; other alloys also available. The shell can be fabricated from a differing material when only one side will be exposed to corrosive conditions.

SUPERMAX PLATE RANGE (LENGTH, M M (FT))

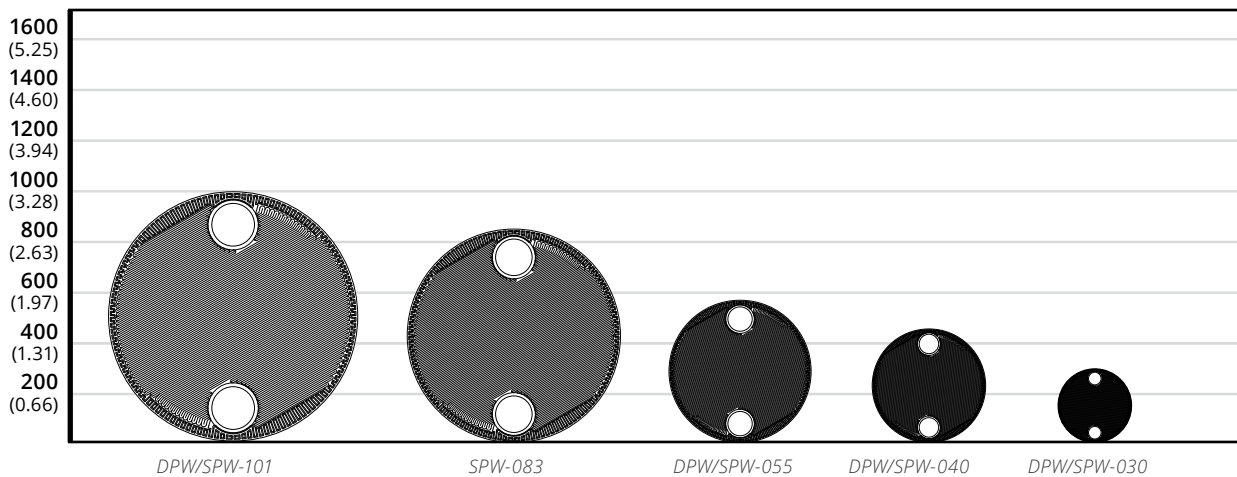



NOVUSBLOC®

For increased durability and energy efficiency

AVAILABLE FOR GLOBAL ENERGY INTENSIVE MARKETS THE NOVUSBLOC WELDED PLATE HEAT EXCHANGER ENCOMPASSES A TRANTER PREMIUM DESIGN CONCEPT OFFERING A SIGNIFICANT BOOST IN HEAT EXCHANGE PERFORMANCE AND DURABILITY FOR THESE PROCESSES.

THE NOVUSBLOC COMES IN FOUR (4) DIFFERENT MODELS

Available for global energy intensive markets the NovusBloc welded plate heat exchanger encompasses a Tranter premium design concept offering a significant boost in heat exchange performance and durability for these processes.

As confirmed by extensive heat transfer, plus both pressure - and temperature fatigue qualification testing, the NovusBloc offers outstanding potential for reduced unit size, weight and footprint with increased durability in a wide range of applications. The patented design offers unique features - and

benefits, which makes it a truly innovative design adding value to our customers.

The NovusBloc is fully accessible for mechanical cleaning and visual inspection making it our customers' first choice of heat exchanger for applications with high fouling tendency.

The NovusBloc comes in four different models, depending on the user's heat transfer duty requirements.

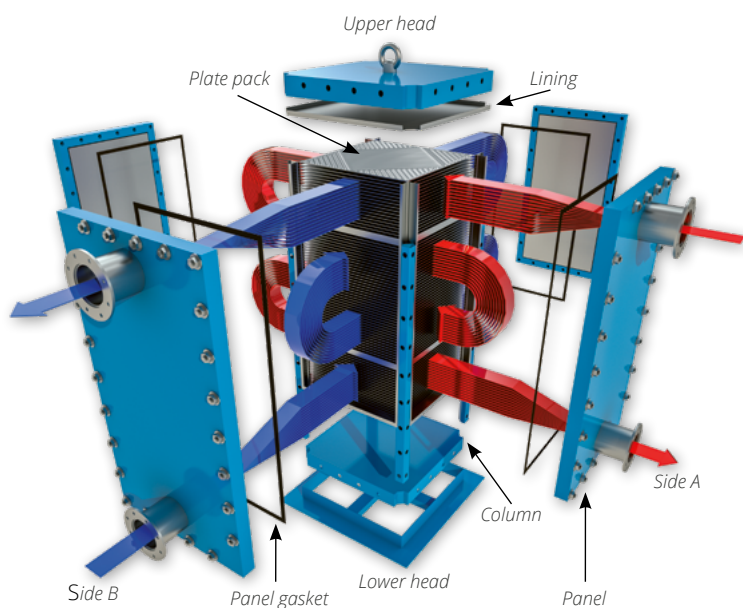

THE NOVUSBLOC WELDED PLATE HEAT EXCHANGER

The NovusBloc is able to withstand tough design conditions and the heat transfer plates can be pressed in many different materials. The product is available for the design specifications tabulated below:

The NovusBloc range incorporates unique premium design approaches in the following areas:

Novel plate design which minimizes unnecessary additional pressure loss at the fluid inlet of each pass and enhances the weld quality of the plate welds.

Highly innovative column lining design which enables the lining to move naturally when exposed to high temperatures thus minimizing failures due to thermal shocks by providing a uniform stress contour and reducing overall stress concentration in the lining.

	Minimum	Maximum
Area (m2/set)	6,6	865
Temperature (°C)	- 50	375
Pressure (bar)	Full vacuum	42
Code / directive	ASME, PED	
Plate material	Stainless steels : SS316L, 254SMO Nickel alloys : C-276, 825 Titanium : Ti.Gr.1, Ti.Gr.11	
Plate thickness	1.0 mm and 1.2 mm	

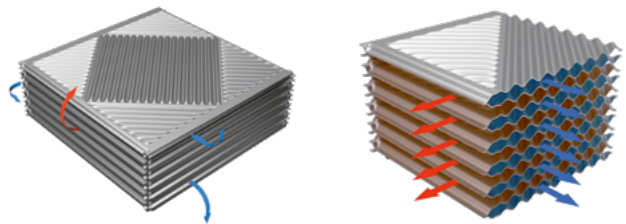

NO.	Model	Heat transfer area sq m	Plate size		Max connection size	Max unit height (mm)
			L (mm)	W (mm)		
1	TB030	0,11	333	333	DN 150 / ANSI 6"	1400
2	TB050	0,27	496	496	DN 300 / ANSI 12"	2150
3	TB075	0,64	762	762	DN 500 / ANSI 20"	3475
4	TB120	1,72	1219	1219	DN 1000 / ANSI 40"	3570



TRANTER FULLSERV® FOR EVERY BRAND

Whatever brands of plate heat exchangers are installed in your facility, Tranter service centers want to ensure that you continue to enjoy best performing condition. Our fast, economical and reliable service means minimal downtime for your exchanger.



TRANTER FULLSERV®

Restoring plate heat exchangers to optimized performance

WITH REGULAR SERVICE AND MAINTENANCE YOU WILL KEEP CONTROL OF YOUR HEAT EXCHANGER'S CONDITIONS AND MAINTAIN OPTIMUM PERFORMANCE. TRANTER HAS EXTENSIVE EXPERIENCE PROVIDING HEAT TRANSFER SOLUTIONS FOR ALL MARKETS, AND OUR MISSION IS TO HELP YOU ACHIEVE THE OPTIMAL SOLUTION WITH REGARD TO PERFORMANCE EFFICIENCY, PAYBACK AND ENERGY CONSERVATION.

GLOBAL NETWORK OF SERVICE EXPERTS AND SERVICE CENTERS

Tranter has a global network of service centers that offers quick and reliable maintenance of your heat transfer equipment. Malfunctions and changes in heat transfer can have severe consequences on operational costs and may affect the product quality. Regular service and maintenance safeguard your heat exchanger's condition and allow you to maintain the optimum performance. Tranter has service centers located worldwide, and are ready to assist with plates, gaskets, assembled plate packs, cleaning services and replacement units to get you back to optimum performance. With Tranter authorized service, you can always be sure that you get the right gaskets, the right plates with our guarantee and expert service.

Regular service and maintenance advantages:

- Prolong equipment lifetime
- Maximize reliability and performance
- Minimize downtime and operating costs

WHY LET TRANTER DO YOUR SERVICE

Tranter has been providing plate heat exchangers specially designed for each customer. This, combined with our extensive experience and solid technical expertise within commercial, industrial, and marine

applications, makes us a reliable service partner for your heat transfer equipment. Allowing our experts to take care of your service jobs will mean that the right tools and methods will be used which will provide time-savings, eliminate mistakes and guarantee same-as-new performance.

Tranter performs service on every brand and model of plate heat exchangers. The service can be made in any of our Service Centers or directly at your site. We will offer tailor-made solutions adapted to your needs, including services such as:

- Hydraulic tightening
- Plate heat exchanger performance evaluation
- Units resize according to actual process data
- Cleaning of plates in chemical baths
- Reconditioning
- Removal of old gaskets
- Keep stock of spare parts customized for you
- Inspections
- Regasketing
- Refurbishments

Tranter's global service and support are available and ready to assist you to receive maximum performance and uptime.





OUR SERVICE FOR EVERY BRAND INCLUDES

On-site services:

- Open, clean & close
- Plate pack swap-out
- Inspection and troubleshooting
- Full site audit
- Training and supervision for maintenance team
- Plate pickup and delivery

Full-shop services:

Plate pack cleaning

- Solvent tank immersion
- Power wash
- Dye penetrant inspection
- Regasketing
- Crated plates in sequential order

Unit refurbishment

- Open unit and remove plates
- Complete plate pack service per above
- Sandblast and paint frame
- Tie bolt restoration/replacement
- Reassembly
- Pressure test to max allowable working pressure (MAWP)

PARTS AVAILABLE

- Full gasket sets
- New plate packs
- Replacement hardware

All Parts and Services listed above are available for all makes and models of plate heat exchangers.

AT THE FOREFRONT OF HEAT EXCHANGER TECHNOLOGY FOR MORE THAN 90 YEARS

Tranter is an American based global manufacturer of gasketed and welded plate heat exchangers and a full-service aftermarket provider for the plate heat exchanger industry. Significant manufacturing, research, design engineering and product development activities are based in the USA, Brazil, Sweden, China, India and Korea and enable responsiveness to local demands. Tranter is represented globally by a network of our own sales companies, licensees and agents.



NORTH AMERICA

Tranter, Inc.
Houston, TX, USA
Tel: +1 940 723 7125
E-mail: sales@tranter.com

INDIA

Tranter India Pvt. Ltd.
Pune, India
Tel: +91 2137 677000
E-mail: salesindia@tranter.com

SOUTH AMERICA

Tranter Ind e Com de Equip. Ltda
Cotia, Brazil
Tel: +55 11 4617-6550
E-mail: brasilsales@tranter.com

CHINA

Tranter Heat Exchangers Co. Ltd.
Beijing, P.R, China
Tel: +86 1064379490
E-mail: info_cn@tranter.com

EMEA

Tranter International AB
Vänernsberg, Sweden
Tel: +46-521-79 98 00
E-mail: sales.support.europe@tranter.com

SOUTH EAST ASIA & OCEANIA

Tranter Heat Exchangers
Singapore, Singapore
Tel: +65-8299-2212
E-mail: info_sea@tranter.com

TRANTER.COM